

CAPITAL FORT

ATKINS & A&A ARCHITECTS

Location: Sofia, Bulgaria
Date of completion: 2014
Area: 2 020 m²
Shop Drawings: 1 315 pcs @ A3
Cut Sheets: XX pcs
Contractor: Kristian Neiko

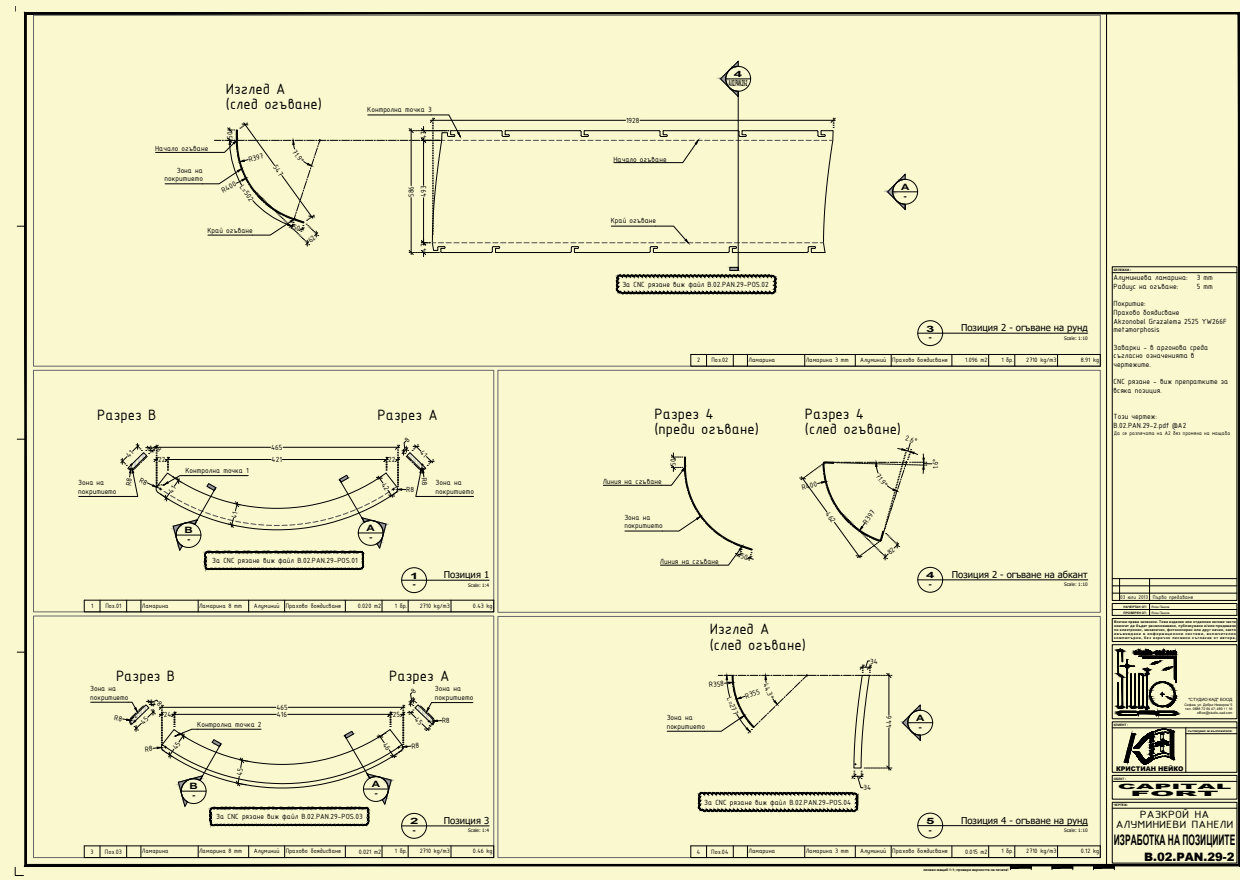
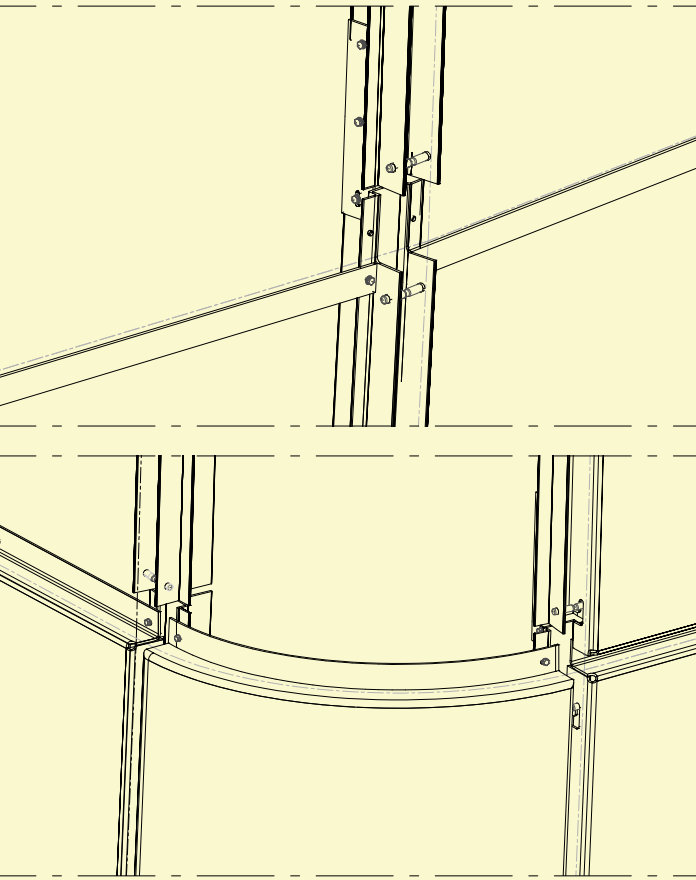
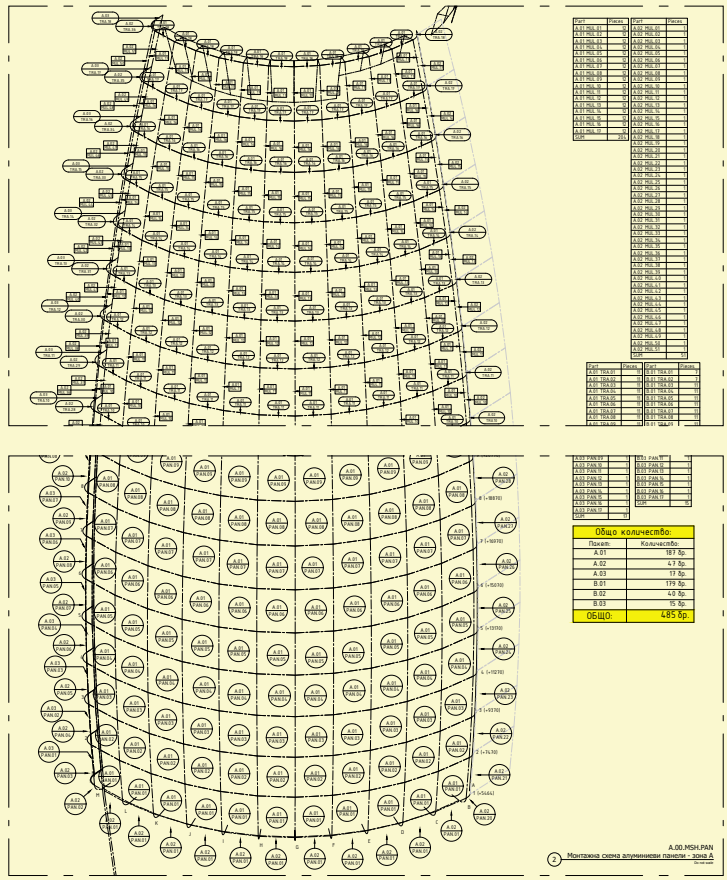
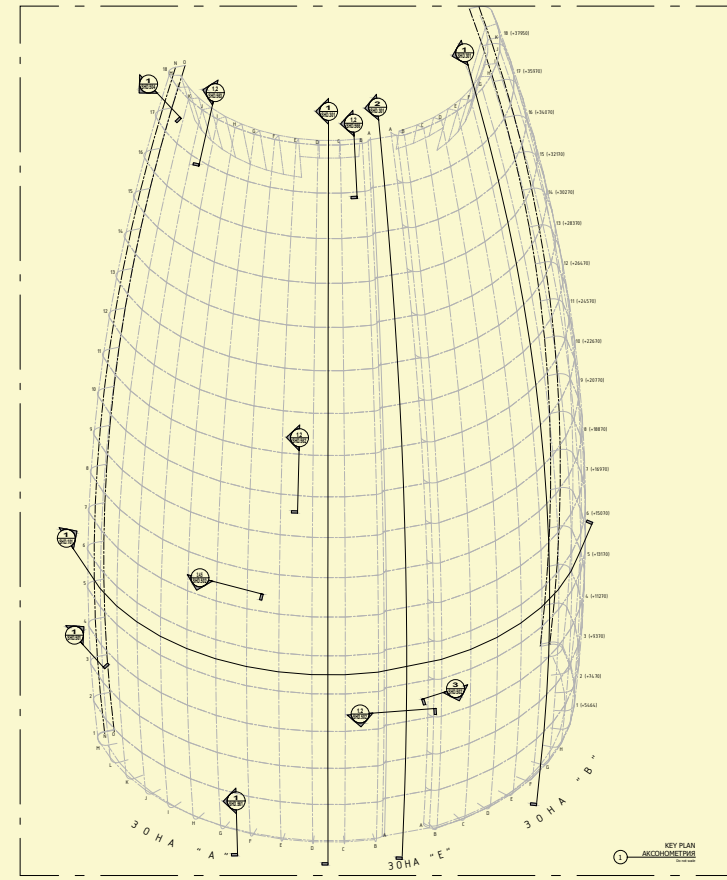
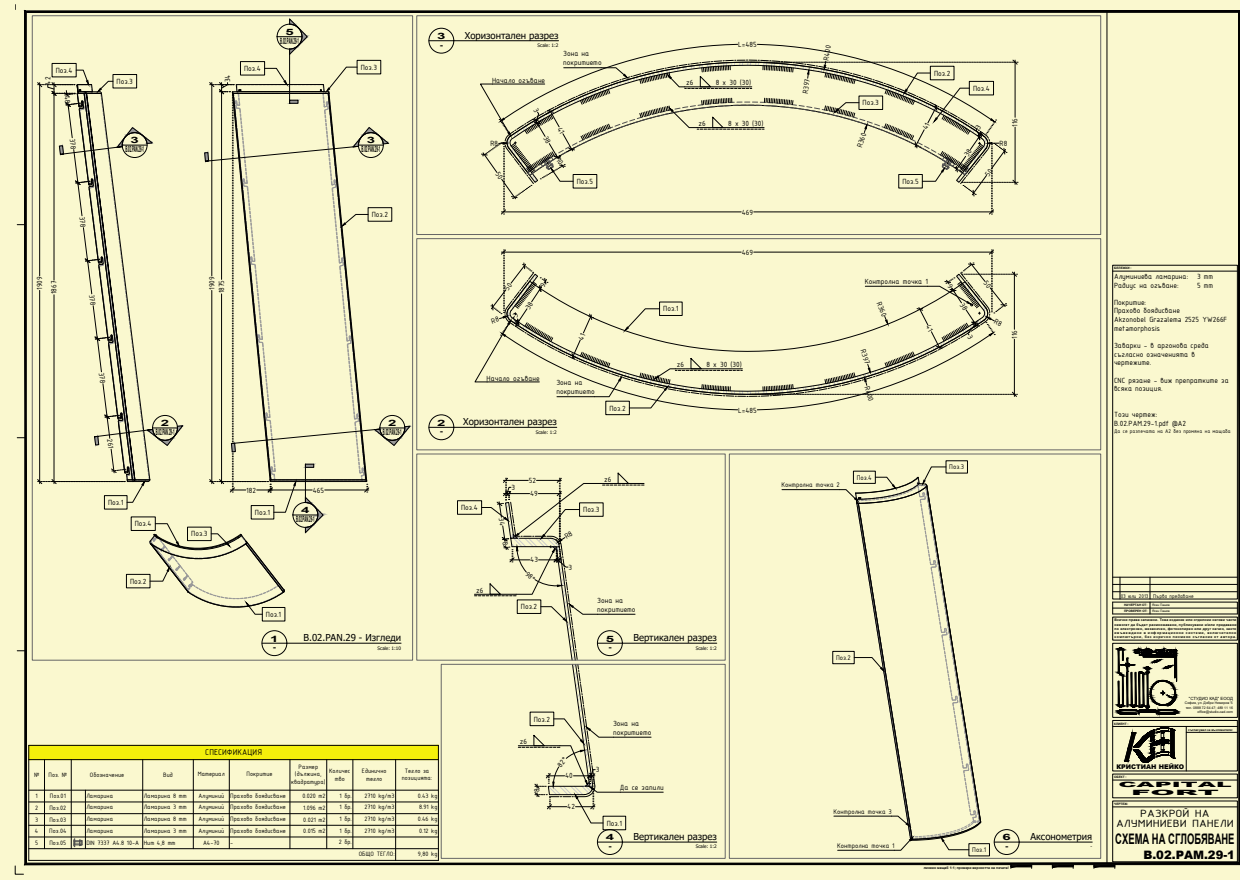
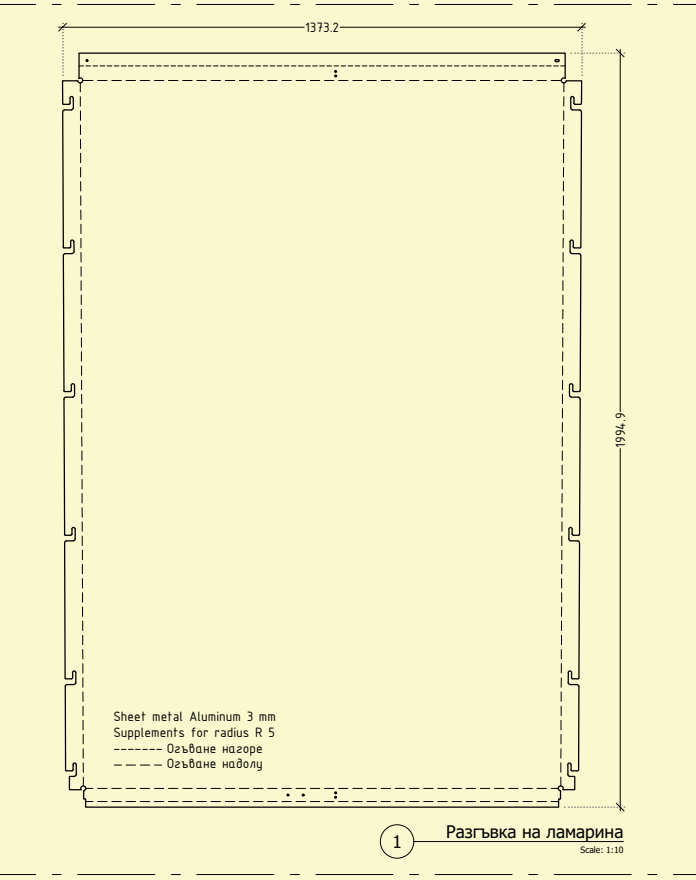
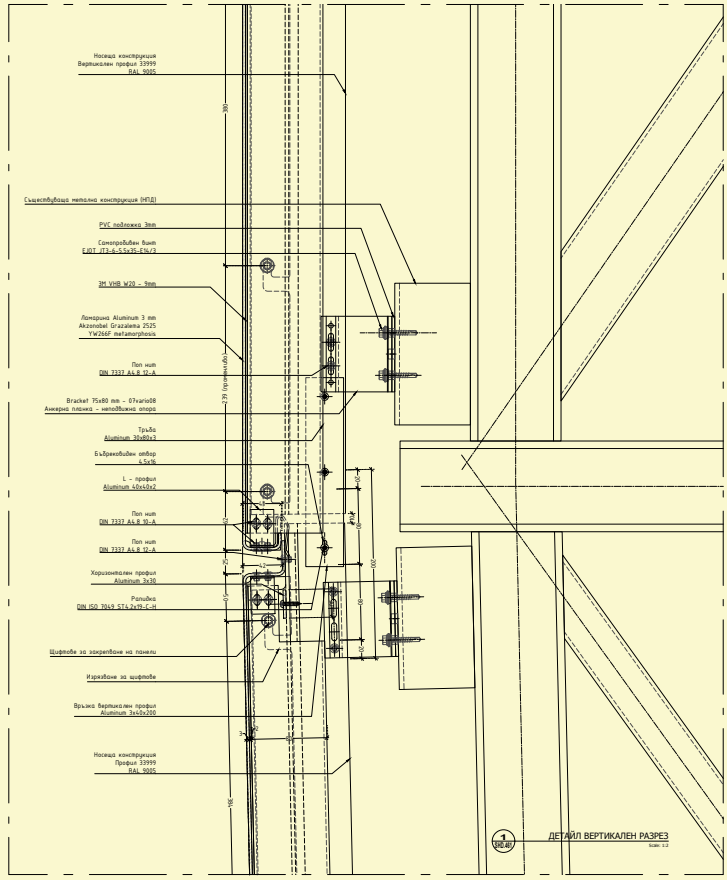
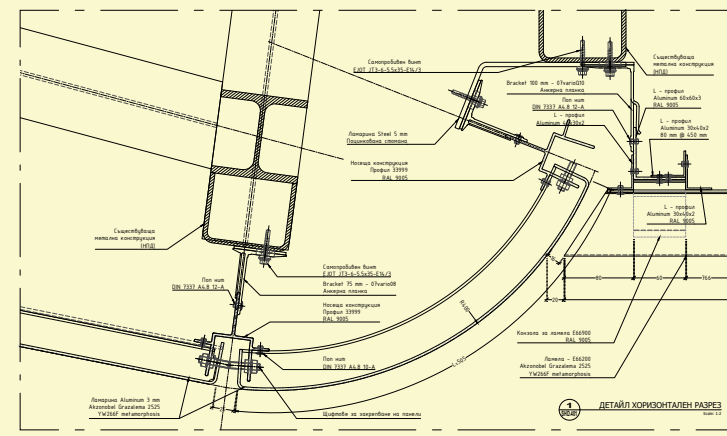

STUDIO CAD
Scope of Services:
Shop drawings & Workshop drawings for:
Aluminum sheet panels